



Leading Conversion Technology for Power Resilience

STABILITI SERIES 30 KW

Installation & Operations Manual V1.0

SMART POWER CONVERSION FOR THE ENERGY REVOLUTION

- AVAILABLE IN MULTIPORT (AC/DC/DC) AND DUAL PORT (AC/DC) VERSIONS
Stabiliti 30C3: AC/DC/DC
Stabiliti 30C: AC/DC
- INTEGRATES SOLAR AND STORAGE IN ONE COMPACT ENCLOSURE
Simplifies system installation, maintenance and control
- SUPPORTS WIDE RANGE OF ENERGY MANAGEMENT APPLICATIONS
AC Microgrids
DC Microgrids
Peak Shaving and Energy Arbitrage
Electric Vehicle Support Equipment "EVSE"
- PROVIDES GALVANIC ISOLATION BETWEEN AC AND DC PORTS
Extends Battery Life
Enhances Safety



Copyright © 2023. Construction électroniques & telecommunications S.A.
All rights reserved. The contents in document are subject to change without notice.
The products presented are protected by several international patents and trademarks.
Address: CE+T S.a, Rue du Charbonnage 12, B 4020 Wandre, Belgium
www.cet-power.com - info@cet-power.com



Disclaimer

This document is provided “as is” and CE+T makes no representations warranties, expressed or implied, with respect to the information contained herein. CE+T has made reasonable efforts to ensure the accuracy of information herein and at the time of publication. However, information is constantly evolving and CE+T does not purport the information provided is correct, comprehensive or exhaustive. This document is for informational purposes only. You should not act upon information without consulting CE+T or its authorized distributors.

© Copyright 2023, CE+T, All rights reserved. No parts of this document may be reproduced in any form without the express written permission of CE+T. The CE+T logo are trademarks of CE+T. All other trademarks and service marks belong to their respective owners.

Revision History

Version	Release date (MM/DD/YYYY)	Modified page number	Modifications
1.0	08/25/2023	-	First release of the manual



Table of Contents

1. Introduction to CE+T	5
2. Glossary of Terms	6
3. Introduction and Purpose	7
3.1 Key Warranty Conditions and Exclusions:	7
3.2 RMA and Service Contact	8
4. Important safety instructions.....	9
4.1 Safety Instructions: All Installations	9
4.2 Safety Instructions: Battery Installations.....	10
4.3 Safety Instructions: Additional	10
4.4 Safety Instructions: Handling.....	11
4.6 Integrated Safety Features.....	11
4.7 Ground Fault Detection – Ground Referenced Systems	11
4.8 Ground Fault Detection – Floating Systems.....	12
4.9 Ground Fault Detection – 4-Wire Bipolar Systems (DC2 only)	12
4.10 DC Over/Under Voltage Fault Detection	12
4.11 AC Current Fault Detection.....	12
4.12 AC Frequency and Voltage Fault Detection	12
4.13 Regulatory Information	12
5. System Specifications.....	13
6. Unpacking and Mounting the Converter.....	14
6.1 Converter Mounting	14
6.2 Clearances for Converter Mounting:	15
6.3 Converter Removal and Preparation for Shipment.....	17
7. AC and DC Terminals - Wiring and Installation	18
7.1 Converter Ground	19
7.2 AC Wiring	19
7.3 AC External Circuit Protection and Disconnect.....	20
7.4 DC Wiring	20
7.5 DC Terminal Connection Overview	20
7.6 DC Wiring Options.....	21
7.7 Connecting a Floating Battery and/or Floating PV Array to DC2 and DC3	22
7.8 Connecting a 4-Wire Bipolar Battery on DC2	23
7.9 DC2 and DC3 External Circuit Protection and Disconnect	23
7.10 Verification of Electrical Connections	23
8. Operating and Shutdown Conditions	25
9. Maintenance and Troubleshooting.....	26
9.1 Annual Preventive Maintenance.....	26



9.2	Verify Proper Airflow	26
9.3	Power Terminals Torque Check	26
9.4	Cooling System Inspection	27
9.5	Converter Troubleshooting	27
9.6	Clearing GFDI Faults- Ground Referenced Applications.....	28
9.7	Clearing GFDI Faults - Floating Applications	28
9.8	Front Panel Display	28
9.9	Converter Fault/Status Codes	29
10.	Fault Overview	30
10.1	Fault Handling	30
10.2	Fault Logging via the Front Panel Display	31
11.	Warranty.....	33

1. Introduction to CE+T

CE+T manufactures and markets a wide range of backup power systems for commercial and industrial customers with critical requirements. CE+T Power was formed in 1936 with international facilities in Belgium, China, India and the USA (Atlanta). CE+T Power puts 60+ years expertise in power conversion together with worldwide presence to provide customized solutions and extended service 24/7 - 365 days per year.

CE+ T Power was formed to provide turn-key power and energy management solutions for datacenters, utilities and C&I customers in North America.

The Company offers products that:

- Reduce environmental footprint of energy usage and TCO;
- Maximize reliability and resilience;
- Allow the seamless blending of power between various energy sources;
- Offer harmonious integration of renewables, stored energy and the grid;
- Offer energy management features combined with energy autonomy;
- Allows utilization of dormant infrastructure to support the grid.

2. Glossary of Terms

Acronym or Term	Full Expression
AWG	American Wire Gauge
CEC	California Energy Commission
CPU	Central Processing Unit
Converter	CE+T Power Converter: Stabiliti 30C, Stabiliti 30C3
CSA	Canadian Standards Association
DMM	Digital Multi-Meter
FRU	Field Replaceable Unit
GFDI	Ground Fault Detection Current
IFM	Insulation Fault Measurement
IMI	Isolation Monitor Interrupter
LCD	Liquid Crystal Display
MPPT	Maximum Power Point Tracking
PCB	Printed Circuit Board
PCS	Power Conversion System
PV	Photovoltaic

3. Introduction and Purpose

The purpose of this manual is to describe the proper operation, maintenance, and troubleshooting of the CE+T Stabiliti™ 30C3 Multiport Power Converter System (“PCS” or “Converter”) and the Stabiliti™ 30C Dual Port PCS.

The 30C3 PCS uses CE+T’s proprietary Power Packet Switching Architecture™ (“PPSA”) to efficiently transfer and manage power flows between three bi-directional power ports: AC1, DC2, and DC3:

- AC1 is a 3-Wire, 3-Phase AC port.
- DC2 is a DC port typically dedicated to battery-based energy storage systems.
- DC3 is an auxiliary DC port for use with a second battery system, or a PV Array.

The 30C is a Dual Port PCS based on the 30C3 platform. The primary difference is that the 30C Port DC3 power electronics are depopulated and disabled at the factory. The 30C has the following power port configuration:

- AC1 is a 3-Wire, 3-Phase bidirectional AC power port.
- DC2 is a DC port typically dedicated to battery-based energy storage systems.

3.1 Key Warranty Conditions and Exclusions:

In no event shall this Warranty cover any defect, loss, damage, failure or other nonconformity of a Converter (“Excluded Defect”) that are directly or indirectly caused by or arise out of any of the following:

- Failure to commission the Converter within 12 months from the date of the CE+T commercial invoice, or if the Converter has been commissioned, and thereafter shut down or depowered for a period in excess of 12 months;
- Failure to install a remote and secure ethernet network connection to each Converter installed at the site;
- Alterations or modifications to a Converter including repairs other than by CE+T or its authorized contractors including, but not limited to, breakage of a Converter’s seal without prior CE+T written consent; drilling through cabinet, etc.
- Warrantee’s or any third-party’s equipment, including, without limitation, components of any system a Converter is integrated into by Warrantee;
- Improper or non-standard installation or operation;
- Insufficient ventilation of the Converter and any consequential thermal damages.
- Corrosion due to exposure to aggressive atmospheres or environmental conditions outside the scope of design.
- Failure to observe applicable safety regulations (UL, CSA, VDE, IEC, etc.)
- Use or operation with defective electrical and/or mechanical equipment;
- A force majeure occurrence, including, without limitation, lightning, overvoltage, severe weather, fire, earthquakes and floods, pest damage, or the influence of foreign objects;
- Improper handling during transportation or storage or damage during shipping;
- Failures and/or faults in relation with any third-party accessories;
- Damage or failure caused by negligence, an accident, an object striking the unit, fire, theft, vandalism, contamination, freezing, unapproved installation, modifying or altering the Converter, or external influences such as, but not limited to, environmental exposure, abnormal grid power quality, and/or any other misuse;



- This warranty only applies to defects in workmanship and materials which does not include claims involving regulatory compliance. To make sure your Converter meets the applicable regulatory requirements which are in place at the time of purchase, please see the applicable Product Manuals and/or your sales contract.
- The items below are expressly not covered by this CE+T Limited Factory Warranty:
- All items not originally sold by CE+T including, but not limited to, installed cables, controllers, (rechargeable) batteries, Current Transformers (CT), Voltage Transformers (VT), and communications devices;
- Consumables and parts subject to regular wear and tear (including, but not limited to, varistors, surge arresters, string fuses, ESS handles, filters, (rechargeable) batteries, or overvoltage protection devices);
- Cosmetic or finish defects which do not directly influence energy production, or degrade form, fit, function;
- The warranty does not cover travel and accommodation costs as well as onsite assembly, installation, or maintenance costs related to repair or replacement of the Converter.
- Changes to the existing PV system, the building installation and the like, or any expenditure of time and the costs resulting from this are not covered by the warranty;
- Compensation for damages related to loss of power production or business operation or any expenses incurred by customer towards repair, removal and/or replacement of the Converter (including but not limited to labor, transportation, temporary power);
- Damages arising because the use of the Converter for the intended purpose is no longer possible or only possible with restrictions as a result of amendments to the statutory provisions applicable to the operation of the Converter made after the delivery of the Converter.

3.2 RMA and Service Contact

Do not ship or return the Converter without prior authorization from CE+T. A Return Material Authorization (RMA) number must first be obtained from CE+T’s customer service department. Please provide the following information at the time of the RMA Request:

- Original registration
- Site address, Installation date, Power On date, Commissioning date.
- Battery type and size
- Stabiliti serial number
- Copy of system SLD and Photos of the Installation
- Maintenance records and any applicable site test reports
- Date of failure Fault Logs, and observed Power-On-Self-Test (POST) Log result

Use the following contact information for all technical support:

Mail	Email & Phone	Warranty
CE+T America 300 Shawnee North Drive, Suite 700, Suwanee-Atlanta, 30024 Georgia Attn: Technical Support	For technical support: tech.support@cetamerica.com For warranty claims: tech.support@cetamerica.com +1 855-669-4627	Online Warranty Registration tech.support@cetamerica.com

4. Important safety instructions

Converter models covered in this manual: 30C and 30C3

Save these instructions

This manual contains important instructions for the CE+T 30C3 and 30C Converters. All wiring must be in accordance with the National Electric Code ANSI/NFPA 70.

The following safety notices are used in this manual:



Danger - Procedures or situations that require action to prevent personal injury or damage to equipment.



Warning - Indicates a potentially hazardous situation that, if not avoided, can result in serious injury or death.



Important information: Includes key information for the operation of this equipment or specific instructions to maintain the warranty.

4.1 Safety Instructions: All Installations



Danger - This product includes Ground Fault Protection for both grounded and ungrounded operation of PV systems. All instructions regarding the configuration of this device must be followed. Failure to follow may result in injury, death, or damage to equipment. All GFDI related information will be marked with the symbol below:



Danger – To avoid an electric shock, verify that the Converter's external AC and DC Disconnects are open (off). A minimum wait time of five (5) minutes is required after opening AC and DC Disconnects to assure that the Converter's internal capacitors have discharged to zero voltage before performing any work on the Converter. Utilize lockout /tagout procedures to ensure that both AC and DC Disconnects remain in the off position during all service periods.



Warning – This photovoltaic rapid shutdown equipment (RSE) does not perform all the functions of a rapid shutdown system (RSS). This RSE must be installed with other equipment to form a complete RSS that meets the requirements of NEC (NFPA 70) section 690.12 for controlled conductors outside the array. Other equipment installed in or on this PV system may adversely affect the operation of the PVRSS. It is the responsibility of the installer to ensure that the completed PV system meets the rapid shut down functional requirements. This equipment must be installed according to the manufacturer's installation instructions.

4.2 Safety Instructions: Battery Installations



Danger – The enclosure contains exposed high voltage conductors. The enclosure front access door must remain closed, except during installation, commissioning, or maintenance by trained service personnel. Do not open the front door if extreme moisture is present (rain, snow, or heavy dew).



Danger – To avoid an electric shock, verify that the Converter's external AC and DC Disconnects are open (off). A minimum wait time of five (5) minutes is required after opening AC and DC Disconnects to assure that the Converter's internal capacitors have discharged to zero voltage before performing any work on the Converter. Utilize lockout/tagout procedures to ensure that both AC and DC Disconnects remain in the off position during all service periods.



Warning – These instructions DO NOT contain any information on the operation of battery systems outside of this product. Refer the manufacturer of the battery system for installation and servicing instructions.

4.3 Safety Instructions: Additional



Danger – The enclosure contains exposed high voltage conductors. The enclosure's front door must remain closed, except during installation, commissioning, or maintenance by trained service personnel. Do not open the front door if extreme moisture is present (rain, snow, or heavy dew).



Danger – Ensure that the equipment is adequately installed and grounded per this manual and all applicable codes.



Danger – Do not leave foreign objects in the Converter enclosure. Keep the area around the enclosure clear of trash, debris, and other combustible materials.



Warning – Personnel Qualification: Inspections and operations requiring access to lethal AC or DC voltages, should only be performed by qualified personnel.



Warning – All field wiring must conform to the codes set forth in the National Electric Code ANSI/NFPA 70.



Warning – Electrostatic Discharge (ESD) Damage: The Converter contains ESD-sensitive equipment. Failure to use ESD control measures while servicing the equipment may result in component damage and void the warranty.



Warning – Service and maintain the Converter in accordance with applicable CE+T procedures. Discontinue Converter use until all equipment defects and safety hazard have been cured. Replace any damaged warning or precautionary labels.

4.4 Safety Instructions: Handling



Warning – The 30C3 and 30C Converters weigh approximately 135 pounds. They are designed to be transported and wall-mounted by two people, without the use of lift or power equipment. If lift or power equipment is used to move, or lift the Converter, follow all safety rules. Failure to do so could result in personal injury or equipment damage.



Warning – An unpacked Converter should be stored on its back, in a secure and dry location prior to vertical mounting installation.

4.6 Integrated Safety Features

The 30C3 and 30C Converters incorporate the following safety features:

Table 1: Converter Safety Features

Feature	Action
Hinged Front Door	Prevents access to hazardous voltages and protects internal circuitry.
DC Ground Fault Detection	Takes Converter off-line when DC input ground fault is detected on either the DC2 or DC3 Ports. Both GFDI (ground referenced connection) and IMI (floating connection) are supported.
DC Overcurrent and Overvoltage Detection.	The Converter will shut down immediately if DC input voltages or currents are out of specified range.
AC Overcurrent and over/under Voltage Detection.	The Converter will shut down immediately if AC input voltages or currents are out of specified range.
AC Frequency Out of Range	The Converter will shut down if the grid frequency is out of specified range.
Anti-islanding protection	The Converter will shut down immediately after detecting any of the AC faults described above. Note: A five (5) minute restart timer is enabled on all grid-fault events.

4.7 Ground Fault Detection – Ground Referenced Systems

For ground referenced monopole battery and/or PV array connections, the negative common leg of DC2 and DC3 is referenced to earth ground through a 1 A GFDI fuse to detect ground fault conditions. If such conditions are detected, the Converter is automatically shut down and taken off-line. The Converter will not attempt to restart until the fault condition is cleared, and AC Power is cycled.

If the ground fault detection fuse shared between DC2 and DC3 is blown as a result of a fault event, it must be replaced in order for the Converter to attempt restart. Ground Faults are indicated on the Front Panel Display and are also available via the Modbus TCP or Modbus RTU communication interfaces.



4.8 Ground Fault Detection – Floating Systems

Floating battery or PV Arrays utilize an onboard “IMI” ground fault detection scheme. This enables the converter to measure the leakage to ground of the DC Power source. If leakage to ground currents are present past the limits set in UL1741 then the unit will fault and prevent operation until the fault is cleared from the DC source. **In the event of an “IMI” fault, the fault can only be cleared by cycling AC power to the unit.**

4.9 Ground Fault Detection – 4-Wire Bipolar Systems (DC2 only)

For 4-wire bipolar battery and/or PV array connections, the GFDI sense inputs (T5 and T6) are utilized with and referenced to ground through a 1 A GFDI fuse to detect ground fault conditions. If such conditions are detected, the Converter is automatically shut down and taken off-line. The Converter will not attempt to restart until the fault condition is cleared and AC Power is cycled.

If the ground fault detection fuse tied to the GFDI sense circuits is blown as a result of a fault event, it must be replaced in order for the Converter to attempt restart. Ground Faults are indicated on the Front Panel Display and are also available via the Modbus RTU or Modbus TCP communication interfaces.

4.10 DC Over/Under Voltage Fault Detection

The Converter also has DC over-voltage (default is 1000 Vdc) and DC under-voltage (default is 100 Vdc) detection circuitry. If these limits are exceeded the Converter will shut down, or if commanded to make power, will not start. These default limits are easily changed via the Modbus interface; however, they cannot be programmed above the 1000 Vdc factory maximum.

4.11 AC Current Fault Detection

The output voltage is synchronized to the AC utility line. The Converter operates as a current source following the grid voltage waveform (“voltage-following”). Should the Converter experience an AC current fault condition, it is automatically shut down and taken off-line. The Converter is shipped from the factory with a default five (5) minute restart countdown timer.

4.12 AC Frequency and Voltage Fault Detection

The quality of the power delivered to the utility line must meet or exceed the requirements as specified in IEEE 1547a. If the utility frequency or voltage shifts outside the regulatory specified limits, the Converter will automatically detect the condition and shutdown. The Converter is shipped from the factory with a default five (5) minute restart counter for AC over/under Frequency limit faults and AC over/under voltage limit faults.

4.13 Regulatory Information

The 30C3 Multiport Converters and 30C Dual Port Converters are certified to the following standards for the North American market:

- **UL 1741 / UL1741SA:** Standard for Battery Converters, Converters, Controllers, and Interconnection System Equipment for Use with Distributed Energy Resources
- **IEEE 1547a:** Distributed Resources Interconnection and Interoperability with the Grid
- **UL 1998:** Software in Programmable Components

5. System Specifications

Maximum AC Input Voltage	528 Vac
Maximum DC Input Voltage	1000 Vdc
AC Operating Voltage Range	422 to 528 Vac
DC Operating Voltage Range	100 to 1000 Vdc
DC Maximum Input Current	60 A
DC Minimum Start-up Current	1 A
AC Maximum Input Current	44 A
AC Minimum Start-up Current	1 A
Maximum Input Source Backfeed Current to Input Source	0 A
Output Power Factor Range	0.75 Leading to 0.75 Lagging
Operating Frequency Range	55 to 65 Hz
Nominal AC Output Voltage	480 Vac
Nominal DC Output Voltage	750 Vdc
Nominal Output Frequency	60 Hz
Maximum AC Continuous Output Power	29.99 kW
Maximum DC Continuous Power	30 kW
Maximum AC output overcurrent protection (software)	44 A RMS
Maximum DC output overcurrent protection (software)	60 A
DC Charging Output Voltage Range	100 to 1000 Vdc
Utility Interconnection Voltage and Frequency Trip Limits and Trip Times	UL 1547.1 Compliant, see Tables 6 and 7.
Synchronization In-rush Current	4.4 A
Trip Time Accuracy	20 mS
Trip Limit Accuracy Voltage	6 Volts
Trip Limit Accuracy Frequency	.05 hz
Temperature Range (full power operation)	-25 °C to 50 °C
Maximum Operating Temperature (output derated above 50 °C)	60 °C
Typical Efficiency	95%
Maximum Efficiency	95.5%
Tare Losses	15 W
External Aux Power supply voltage range input to Converter	22 to 26 Vdc
GFDI trip limit	1 A
IMI trip level	< 3.8 k Ohms to ground
Communication Interfaces	RS485 Modbus RTU-2W / Modbus TCP Over Ethernet
NEMA rating	3R
Weight	Approximately 135 lbs.

6. Unpacking and Mounting the Converter



Two-man lift: Observe all safe practices while moving or mounting the Converter. The Converter can be set safely on its back or vertical if properly supported until it is ready to be mounted.



Storage before installation: Store the Converter in its original shipping container indoors in a non-condensing environment between the range of **-40 °C to 85 °C**.



Disposal of shipping material: Please adhere to all local recycling if you choose to dispose of the shipping material. You may also save the material in the event unit must be transported to another location.

1. Box
2. Mounting Bracket
3. Mounting Hardware
4. Foam
5. Customer Quick Link Card
6. Converter

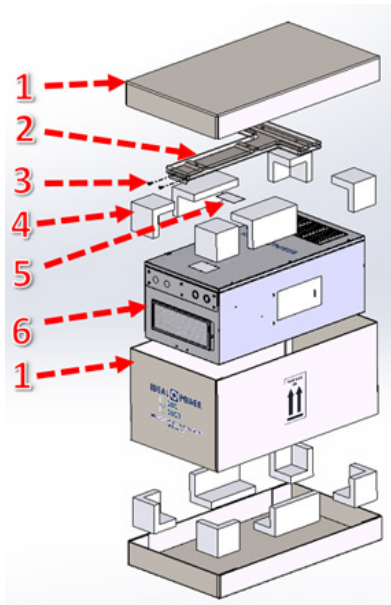

Figure 1: CE+T Approved Shipping Container

6.1 Converter Mounting

The 30C3 and 30C Converters, when installed on their wall mounting bracket, weigh approximately 143 pounds. External dimensions are 20.7" W x 40" H x 16.6" D. The PCS **MUST** always be installed in a vertical upright position for final installation, as well as evaluation purposes. Do not block cooling airflow to the bottom air intake filter, or the exhaust output, which is located on the upper door face of the unit.

6.2 Clearances for Converter Mounting:

- Minimum bottom clearance requirement: Outdoors or Indoors: 18 inches above. Violation of this clearance will void the warranty.
- Minimum front clearance requirement: 36 inches from the front of the Converter must be clear of flammable materials or obstructions.
- Minimum side clearance requirement: 4 inches from the left and right sides of the Converter must be observed. The Converter's product label must be clearly visible at all times.

Warning: The unit must be mounted upright and level for the closed loop liquid cooling system to work correctly.



Figure 2: Enclosure Exterior

- Step 1.** Secure the wall mounting bracket to the desired surface using either a metal Uni-strut type railing rated for the Converters weight or a concrete wall. Ensure mounting bracket is level within +/- 5 degree.
- Step 2.** Using a two-man lift procedure carefully lift the Converter and set it on the provided wall bracket.
- Step 3.** Secure the bottom two bolts located at the bottom plate of wall bracket to the Converter. Torque these to 40-inch pounds.
- Step 4.** Confirm the Converter is mounted level and that the minimum clearance has been met.

30C3	~135 lbs.
30C	~133 lbs.
Mounting Bracket	~ 8 lbs.

Table 2: Converter Weight

Secure the wall mounting bracket to the desired surface using either a metal Uni-strut type railing rated for the Converters weight or a concrete wall. Ensure mounting bracket is level within +/- 5 degree.

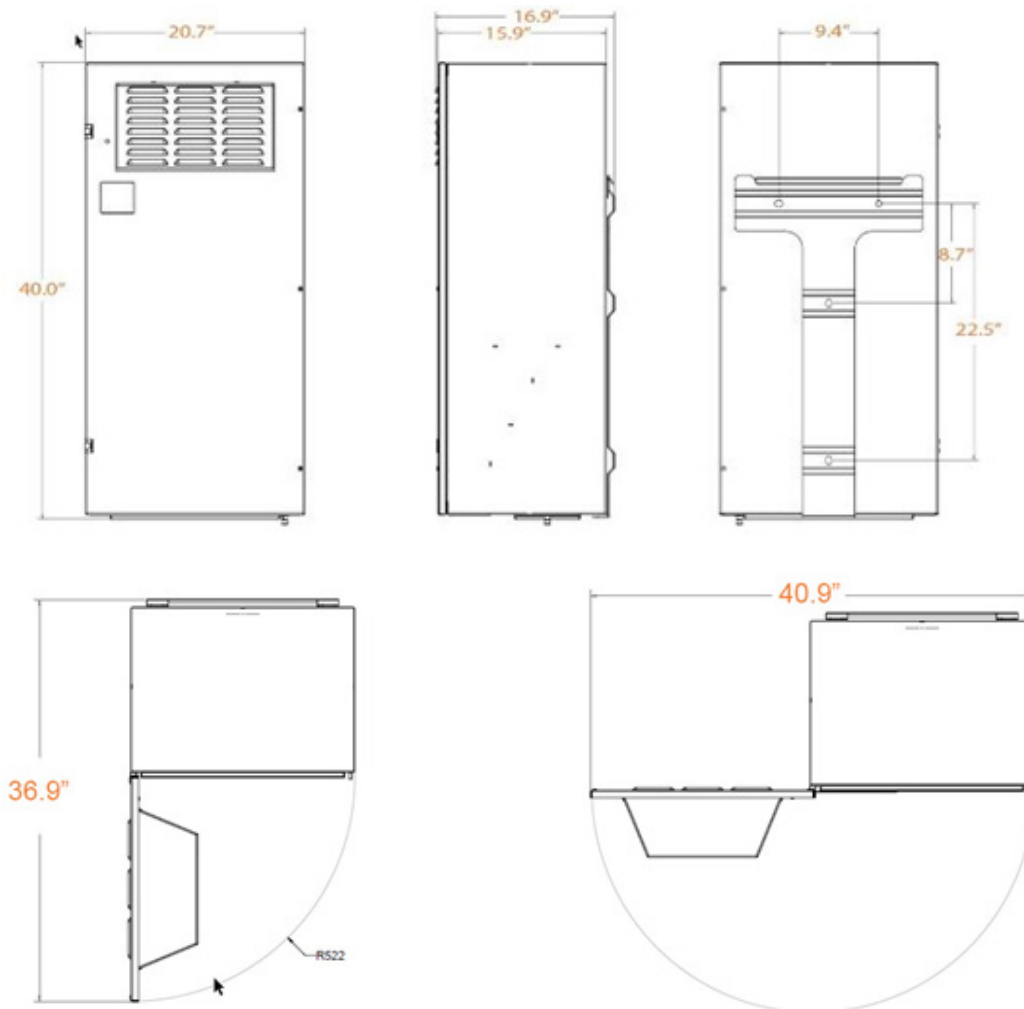

Figure 3: Door Clearance Guide

The PCS installation must allow the front door to swing freely open for service purposes. Although 90-degree and 180-degree swing angles are shown above, a minimum swing angle of 135 degrees is required to ensure that access for initial system wiring and ongoing maintenance of the unit is not compromised.



6.3 Converter Removal and Preparation for Shipment

1. Open external AC Disconnect.
2. Open external DC Disconnect(s).
3. Wait five (5) minutes for capacitors to discharge.
4. Open the enclosure's hinged front door using a 2.5 mm Allen Wrench.
5. Using an external DMM, verify that residual AC and DC voltages present at power connectors present no shock risk.
6. Disconnect the AC and DC power cables.
7. Disconnect all Conduit connections.
8. Disconnect Modbus Interface cables, and other low-voltage cables.
9. Disconnect chassis ground connections.
10. Close and secure the front door.
11. Remove the Converter from the wall mount bracket.
12. Package the Converter in CE+T approved packaging (Double wall, B/C fluting box, and foam packing).

7. AC and DC Terminals - Wiring and Installation

Tools Required:

- To open enclosure door – 2.5 mm Allen Wrench.
- To connect field AC and DC wiring – flat blade Screwdriver.
- To connect earth ground safety wiring - flat blade Screwdriver.



Danger – Do not remove or reconfigure the converter's factory wiring. Contact CE+T at customer.support@cet-power.com



Warning – Changing the Converter's DC jumper configuration as it was received from the factory may result in unexpected or unsafe operation. DC jumper configuration must match the approved field wiring configuration. Consult a certified professional before changing the Converter's factory defaults. All ground-referenced and ungrounded connection must be field wired to NEC NFPA 2015 standards.



Warning – All AC wire connections are to be made with UL listed 4-6 AWG copper wire rated for 600 Vac; 40 A. All wires shall be torqued to 45-inch pounds. Use of non-copper conductors is prohibited and will void the Converter's warranty.



Warning - The PCS default configuration supports a 480 Vac line-to-line 60 Hz grid connection.



Warning – Grounding the PCS must be done using the provided ground lug.



Warning – A separate fused AC Disconnect (or AC breaker) and a separate fused DC Disconnect must be installed externally with this Converter.



Important information: - CE+T Stabiliti™ Series 30 kW PCS AC power interfaces are galvanically isolated from all DC source(s).

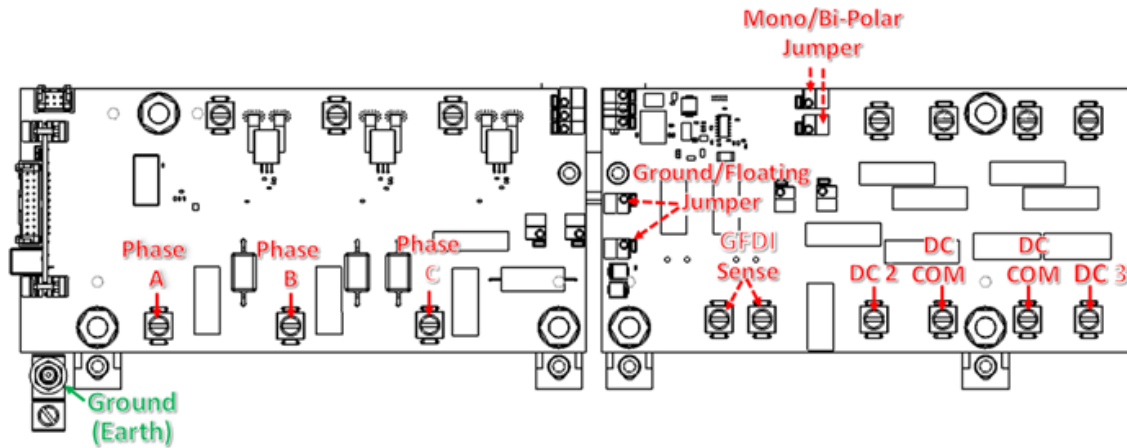

Figure 4: AC1 and DC2/DC3 Interconnect Boards

Terminal Block	Location	Wire Size / Torque
AC Compression Terminals: T4, T5, T6	Bottom of AC1 Wiring Interconnect Board	#4-6 AWG / 45 Inch-pound, copper conductors only
DC Compression Terminals: T5, T6, T7, T8, T9, T10	Bottom of DC2/DC3 Wiring Interconnect Board	#4-6 AWG / 45 Inch-pound, copper conductors only
Ground Terminal	Below AC1 Wiring Interconnect Board	#4-6 AWG / 45 Inch-pound, copper conductors only

Table 3: Terminal Tightening Torques

7.1 Converter Ground

The Converter has an Earth Ground compression terminal that supports up to 4-gauge copper wire for ground connections. All terminations are made to bare wire, using a flat blade screwdriver drive head. No crimping is required when making the ground connection.

7.2 AC Wiring



Warning - Use the provided conduit knockouts located just below the AC Connect Board for all AC conduit connections, any other penetrations to the Converter's enclosure could result in damage, or unsafe operation and will void the unit's warranty.

Connect the 3-480 Vac phase legs to terminals T4, T5, and T6; (Phase A, Phase B, and Phase C), utilizing the compression terminals as described above. For voltage-following applications the rotation of the 3 phases is not critical, as the Converter will sense and follow the AC grid regardless of rotation sequence.

However, voltage forming applications require that all 3 AC phases **MUST** respect correct rotation sequencing. The Converter will immediately fault if an incorrect phase sequence is detected if configured for voltage forming. An external phase sequence tester should be utilized to verify or correct rotation sequencing.

For both voltage-following and voltage forming, power is made between the 3 phase legs. No power is made phase-leg to neutral, and therefore no neutral connection is provided by the Converter.

Torque all AC connections as outlined in “Table 3: Terminal Tightening Torques”, page 19.

7.3 AC External Circuit Protection and Disconnect

The Stabiliti™ must be installed with external circuit protection. A 50 A, 3-Phase, 3-wire AC breaker, rated at 480 Vac, is commonly used for such purposes. In some jurisdictions, this circuit breaker may also be approved for use as a safety disconnect. However, CE+T recommends that you confirm specific AC disconnect requirements with your local Authority Having Jurisdiction (“AHJ”). Some utilities may require an external “red-handle” lockable disconnect, in addition to the protection breaker noted above.

7.4 DC Wiring



Warning - Use the provided conduit knockouts located just below the DC Connect Board for all DC conduit connections, any other penetrations to the Converter’s enclosure could result in damage, or unsafe operation and will void the unit’s warranty.

Terminal	Description	Used by 30C	Used by 30C3
T7	+DC2	YES	YES
T8	-DC2 (DC Common)	YES	YES
T9	-DC3 (DC Common)	NO	YES
T10	+DC3	NO	NO
T5	GFDI Sense	**	**
T6	GFDI Sense	**	**

Table 4: DC Wiring Nomenclature

**Used as the full-current ground reference inputs with 4-wire bipolar wiring on DC2.

DO NOT USE T5 and T6 for floating or ground-referenced monopolar DC2 applications; or in conjunction with DC3. DC3 does not support bipolar wiring.

7.5 DC Terminal Connection Overview

- T7 is the positive battery connection for DC2. T8 is the negative battery connection for DC2. These DC power connections are utilized by both the 30C and 30C3.
- T10 is the positive battery connection for DC3. T9 is the negative battery connection for DC3. These DC power connections are utilized by the 30C3 only.
- GFDI sense inputs (T5 and T6) are used for 4-wire bipolar wiring configurations on DC2 only. Do not connect to these terminals if you are utilizing a floating battery or ground-referenced monopole battery on DC2.
- Note that the negative input for DC2 (T8: DC COM) and the negative input for DC3 (T9: DC COM) are wired together and electrically common behind the Filter Chokes installed on DC2 and DC3.

7.6 DC Wiring Options

The DC2 Port (both 30C3 and 30C) supports: floating, ground-referenced monopolar, and ground-referenced 4-wire bipolar wiring configurations. The DC3 Port supports floating, and ground-referenced monopolar wiring configurations: 4-wire bipolar is NOT supported.

- If DC2 is configured for floating, DC3 MUST be floating. If DC2 is ground-referenced, DC3 MUST be ground-referenced.
- If the DC2 port is configured as 4-wire bipolar, the DC3 Port MUST be floating, and cannot be ground-referenced.
- There are jumpers on the DC2/DC3 interconnection board that must be correctly configured to support the wiring options detailed. Consult the table below for appropriate DC jumper configuration.

DC2 Configuration	DC3 Configuration	Ground Jumper	Monopole Jumper
Floating Monopole	NA (30C only)	Not Installed	Installed
Ground-Referenced Monopole	NA (30C only)	Installed	Installed
3 or 4-wire Bipolar	NA (30C only)	Installed	Not Installed
Floating Monopole	Floating Monopole	Not Installed	Installed
Ground-Referenced Monopole	Ground-Referenced Monopole	Installed	Installed
3 or 4-Wire Bipolar	Ground-Referenced Monopole	Installed	Not Installed

Table 5: DC Jumper Installation Guide

Ground Reference Jumper

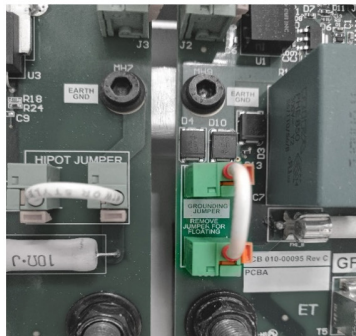

Monopole Jumper

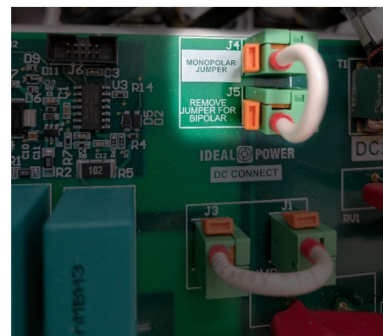

Figure 5: DC2/DC3 Interconnect Board Jumper Locations

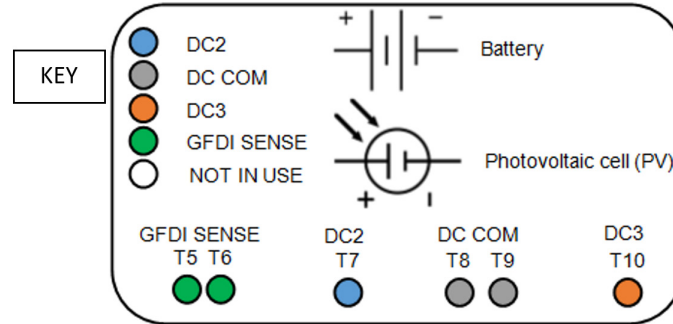

Figure 6: Key to DC Wiring Examples

7.7 Connecting a Floating Battery and/or Floating PV Array to DC2 and DC3

- For 30C3 applications, the positive conductor of each floating power source must be connected to DC2 (T7) and DC3 (T10).
- For 30C3 applications, the negatives of each power source share a common DC negative connection “DC COM” (T8 for DC2 negative and T9 for DC3 negative).
- For 30C applications, the positive conductor of the single floating power source must be connected to DC2 (T7).
- For 30C applications, the negative conductor of the single floating power source must be connected to DC2 (T8).
- T9 and T10 are not utilized by the 30C PCS.

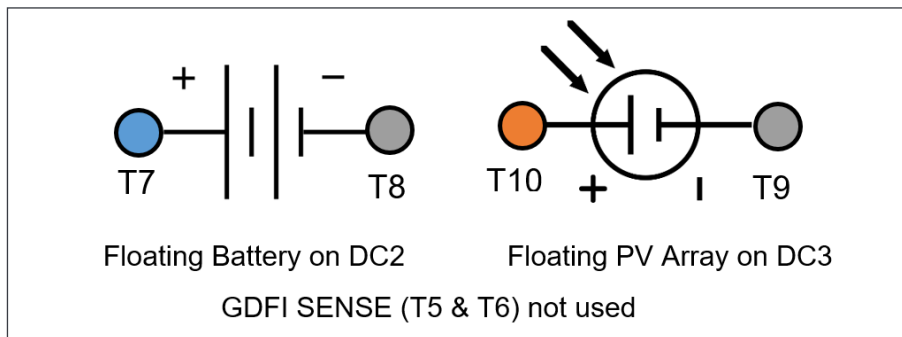

Figure 7: Floating Battery and/or Floating PV Array to DC2 and DC3

7.8 Connecting a 4-Wire Bipolar Battery on DC2

In this bipolar example, note that for 30C3 applications, DC3 MUST support a floating Battery (or PV Array), with its negative leg electrically common with the most negative side of the bipolar connection (T8).

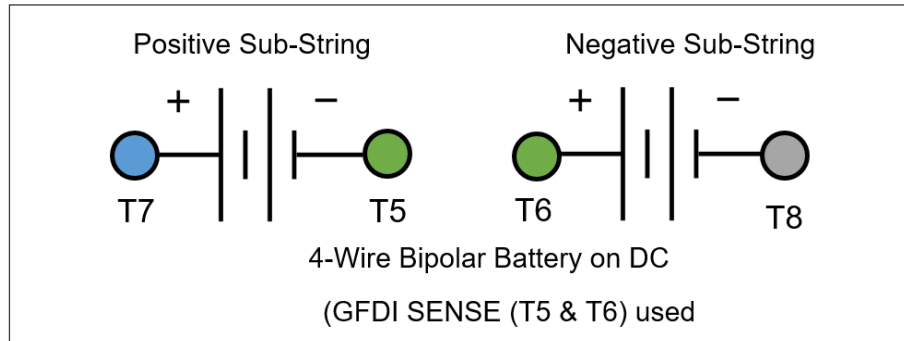

Figure 8: 4-Wire Bipolar Battery on DC2

7.9 DC2 and DC3 External Circuit Protection and Disconnect

The 30C (DC2 only) and 30C3 (DC2 and DC3) must be installed with external fused circuit protection on their DC power ports. A 1000 Vdc rated, 100 A fused PV Disconnect is commonly used for such purposes. However, CE+T recommends that you confirm specific DC disconnect and safety requirements with your local Authority Having Jurisdiction (“AHJ”).

7.10 Verification of Electrical Connections

Use the following procedure to verify final Converter wiring after completing the AC, DC, and Ground wiring as detailed in Section 7, page 18.

High voltages are present, and only qualified personnel following safety procedures detailed in Section 7, page 18 should attempt the following:

1. Open all AC and DC Disconnects.
2. Open the enclosure front door.
3. Close the external AC Disconnect connected to Port AC1.
 - a) Using a DMM on the AC voltage scale, verify that 480 Vac 3-Phase power is present on the AC terminals: measure phase AB voltage, phase BC voltage and phase CA voltage. Measurements from each individual phase-leg to Earth ground should read approximately 277 Vac.
 - b) If observed AC measurements do not meet the above requirements, immediately open the AC Disconnect and remedy AC wiring faults.
4. Close the external DC Disconnect connected to Port DC3 (30C3 applications, not applicable to 30C).
 - a) Using a DMM on the DC voltage scale, measure the DC input voltages.
 - b) If observed DC voltages are higher than 1000 Vdc or outside of PV Array or battery design expectations, open the DC Disconnect and remedy DC wiring faults.



- c) Compare Front-Panel Display voltage measurements to DMM observations.
5. Close the external DC Disconnect connected to Port DC2 (applicable to 30C3 and 30C).
 - a) Using a DMM on the DC voltage scale, measure the DC input voltages.
 - b) If observed DC voltages are higher than 1000 Vdc or outside of PV Array or battery design expectations, open the DC Disconnect and remedy DC wiring faults.
 - c) Compare Front-Panel Display voltage measurements to DMM observations.
6. Close and secure the enclosure front door.

8. Operating and Shutdown Conditions

The Converter is shipped in an idle power state, and will not respond to power export or import commands, as commanded via Modbus, until the following conditions are met:

- All external AC and DC Disconnects are closed.
- No DC Port input ground faults have been detected.
- DC Port input voltages are within the specified operating range, as set by the Modbus Interface.
- There are no sensed fault conditions, as defined in Section 9, page 26.
- AC grid voltage and frequency are within specified IEEE 1547.1 default ranges and islanding is not detected. Voltage and Frequency Ranges are detailed in the tables below.

Voltage Range: (as a % of base voltage)	Clearing Time (s)	Clearing Time: adjustable up to, and including (s)
$V < 45$	0.16	0.16
$45 < V < 60$	1	11
$60 < V < 88$	2	21
$110 < V < 120$	1	13
$V > 120$	0.16	0.16

Table 6: IEEE 1547.1 Default Voltage and Trip Time Ranges

Function	Default Settings		Ranges of Adjustability	
	Frequency (Hz)	Clearing Time (s)	Frequency (Hz)	Clearing Time: adjustable up to, and including (s)
UF1	< 57	0.16	56 to 60	10
UF2	< 59.5	2	56 to 60	300
OF1	> 60.5	2	60 to 64	300
OF2	62	0.16	60 to 64	10

Table 7: IEEE 1547.1 Default Frequency and Trip Time Ranges

9. Maintenance and Troubleshooting

9.1 Annual Preventive Maintenance

The procedures in this section are to be performed only by qualified personnel.

Danger: HIGH VOLTAGE

To eliminate high voltages inside the Converter enclosure:



- All DC Disconnects must be open
- All AC Disconnects must be open
- Wait at least five (5) minutes for internal capacitors to discharge

DO NOT open the enclosure front door until the Converter has been rendered safe in this manner. High DC voltages may be present on terminals of an open GFDI Fuse if the DC Disconnect is NOT open.

After opening the Converter's front door:

1. Using a DMM on the DC voltage scale, measure the DC input voltages, to verify that DC line capacitors have bled down to a safe voltage level.
2. Using a DMM on the AC voltage scale, measure the AC input voltages, to verify at AC line capacitors have bled down to a safe voltage level.

9.2 Verify Proper Airflow

Check the bottom airflow intake filter and ensure that the forced air intake and exhaust vents on the bottom and at the top front of the Converter are not obstructed. Note that under low-power conditions fan speeds and noise levels are quite low.

Remove and clean the filter if the airflow is restricted due to dust or other debris. Replace the filter, if soiled badly.



WARNING: Do not operate the Converter at operating power with the cabinet door open. The Cabinet door must be closed to ensure proper cooling airflow to internal power components.

Do not operate the Converter without the conduit wiring plate installed. The conduit wiring plate must be installed, and all conduit penetrations on the plate must be sealed to ensure proper cooling airflow to internal power components.

9.3 Power Terminals Torque Check

Annually re-torque the power terminals to the specified torque levels in "Table 3: Terminal Tightening Torques", page 19.

1. Open both external DC Disconnects and lockout/tagout in the open position.
2. Open the external AC Disconnect and lockout/tagout in the open position.
3. Wait at least five (5) minutes for the Converter internal capacitors to discharge to safe voltage levels.
4. Open the enclosure front door.

5. Using a DMM on the DC voltage scale, measure the DC input voltages, to verify that DC line capacitors have bled down to a safe voltage level.
6. Using a DMM on the AC voltage scale, measure the AC input voltages, to verify at AC line capacitors have bled down to a safe voltage level.



WARNING: Measure T7 to T8, T10 to T9, and from each terminal to chassis GND.

7. Using a calibrated torque wrench fitted with an slotted screwdriver, tighten the terminals listed to the specified torque levels in “Table 3: Terminal Tightening Torques”, page 19 (torque levels conform to UL 1741: Table 66.1).

9.4 Cooling System Inspection

1. With the Converter operating, verify that the fan is operating correctly, with no appreciable bearing or mechanical noise.
2. Safely shut down the Converter as detailed above (re-torque power connections) and inspect the heat exchanger for blockage or damage.
3. If the heat exchanger is blocked or damaged contact CE+T .
4. With the Converter shut down, remove and inspect bottom fan intake filter by removing the retaining thumbscrew. Clean filter carefully with compressed air and re-assemble, or replace.
5. If the fan is noisy or otherwise suspect, contact CE+T for a replacement unit and installation instructions.

9.5 Converter Troubleshooting

The procedures in this section are to be performed only qualified personnel.



Danger: HIGH VOLTAGE

To eliminate high voltages inside the Converter enclosure:

- All DC Disconnects must be open
- All AC Disconnects must be open
- Wait at least five (5) minutes for internal capacitors to discharge

DO NOT open the enclosure front door until the Converter has been rendered safe in this manner. High DC voltages may be present on terminals of an open GFDI Fuse if DC Disconnect is NOT open.

After opening the Converter's front door:

1. Using a DMM on the DC voltage scale, measure the DC input voltages, to verify that DC line capacitors have bled down to a safe voltage level.
2. Using a DMM on the AC voltage scale, measure the AC input voltages, to verify at AC line capacitors have bled down to a safe voltage level.

9.6 Clearing GFDI Faults- Ground Referenced Applications

In the event of a detected ground fault the Converter will cease exporting or importing power. The fault will be noted on the front panel display. If the fault exceeds 1 A, the ground fault detection fuse will open. The DC2 Port (30C only) and the DC3 Port (30C3 and 30C) both share a ground fault detection circuit and fuse.

If a ground fault is indicated, inspection and repair of wiring should be referred to qualified personnel. Once the ground fault is remedied, check the front panel display for an indication that the detected ground fault condition has cleared. If the display indicates the ground fault interruption fuse has opened, follow the procedure below to replace the ground fault fuse. Use an identical 508 Series 3AB 1 A fuse type for replacement.

9.7 Clearing GFDI Faults - Floating Applications

In the event of a detected ground fault the Converter will cease exporting or importing power. The fault will be noted on the front panel display. In floating applications, an IMI impedance sensing circuit is utilized.

If a ground fault is indicated, inspection and repair of wiring should be referred to qualified personnel. Once the ground fault is remedied, check the front panel display for an indication that the detected ground fault condition has been cleared.

9.8 Front Panel Display

The LCD front panel display of the PCS includes fault indicators and other important PCS information. Two types of fault conditions are reported: Ground Fault and General Faults.

- Ground Fault Indicator 'G' – When this fault indicator is solid color red, there is a Ground Fault within the system. This indicator is dedicated to Fault #0 and Fault #1 as described below.
- General Fault Indicator 'F' – When this fault indicator is solid color red, there is an active fault or a fault that has resulted in a lockdown of the system.

Fault information is provided in the 3rd grouping of text down from the top of the display. The most recent fault is indicated first. For faults that occurred simultaneously, the fault with lowest ID number will be displayed. Second, active Fault Sets 0-3 are displayed in hexadecimal format along with an indicator of how many faults are currently active. An example image is provided below along with its interpretation.

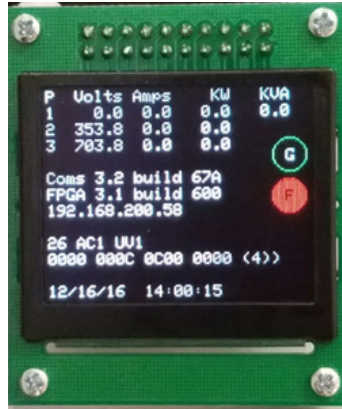

Figure 9: Front Panel Display

Figure 9 Interpretation

26 AC1 UV1: Most recent fault

0000	000C	0C00	0000	(4)
Fault Set 3 None Active	Fault Set 2 34 & 35 Active	Fault Set 1 26 & 27 Active	Fault Set 0 None active	4 active faults

Note that this set of 4 faults are the standard response to a loss of AC supply (utility grid).

9.9 Converter Fault/Status Codes

The Fault and Status codes shown on the Front Panel Display and are also available via the Modbus Interface. Refer to Application Note 303 for monitoring and managing PCS faults via the Modbus Interface. Portions of that document that pertain to the use of the front panel display for fault management are repeated in Section 10, page 30.

10. Fault Overview

- *As noted earlier, the system is installed in an “all Ports idle” configuration state. No Port-to-Port power transfers can or will occur until the system is configured and commanded to move power by the system controller.*
- *Without the system controller present, or an appropriate means to command and monitor the PCS via the Modbus RTU or Modbus TCP interface, other than the front panel display, there is no means to configure, command, or monitor the PCS.*
- *If an Abort fault is active, or a Lockdown fault has occurred, the PCS will not respond to power commands until the fault has cleared.*

10.1 Fault Handling

An CE+T PCS allows for a partly automated fault handling system which operates broadly as follows. When a fault limit is reached or exceeded during operation, the PCS will shut down and flag an Active Fault. Provided the PCS is being run in Automatic Mode, once the fault condition has passed the PCS will clear the Active Fault flag, increment a counter on the associated Occurred Fault then initiate a count-down timer.

Once a count-down timer reaches zero the PCS will attempt to reconnect and resume operating as it was prior to the fault. The PCS may also be operated in Manual Mode, which is intended for manual test or troubleshooting operation. If run in Manual Mode, the PCS will not automatically attempt a restart after a fault countdown.

The PCS has 57 possible faults each of which is assigned one of the severity categories below.

- **Info:** increments the fault counter only – not detailed in this document.
- **Alert:** increments the fault counter only – not detailed in this document.
- **Alarm:** fault is logged – not detailed in this document.
- **Abort 0:** fault is logged, and unit is stopped. Reconnect timer 0 is used for restart.
- **Abort 1:** fault is logged, and unit is stopped. Reconnect timer 1 is used for restart.
- **Abort 2:** fault is logged, and unit is stopped. Reconnect timer 2 is used for restart.
- **Lockdown:** fault is logged, unit stops processing power and requires a manual reset.

The severity levels determine if the fault is simply recorded or whether the converter should be automatically shut down. Fault categories Abort 0-2 are associated with a count-down timer. For these faults, an external acknowledgement or fault reset is not required as is sometimes demanded by other equipment employing latching fault states.

Some faults are not automatically recoverable, such as is the case with a mechanical fan failure, or open ground-fault fuse. These select faults are not assigned a reconnect timer and typically require in-person intervention.

Notably, faults associated with IEEE 1547 voltage & frequency grid limit disconnection are assigned to reconnect timer #0 which has a factory default setting of 300 seconds (5 minutes) to comply with that utility interconnection code requirement. Timers #1 and #2 are 20 seconds by default.

- *Changing the duration of reconnect timer #0 may invalidate your utility interconnection agreement. Do not change this PCS setting without utility review and approval.*

10.2 Fault Logging via the Front Panel Display

The hexadecimal line on the front panel display must be decoded into four, 16-bit binary data fields to determine what faults are currently active. The right most “word” indicates if a fault between 0 to 15 is active; the next word indicates any fault between 16 and 31 which is active, and so forth. Table below further details this active bit mapping.

Fault Set	b15	b14	b13	b12	b11	b10	b9	b8	b7	b6	b5	b4	b3	b2	b1	b0
0	15	14	13	12	11	10	9	8	7	6	5	4	3	2	1	0
1	31	30	29	28	27	26	25	24	23	22	21	20	19	18	17	16
2	47	46	45	44	43	42	41	40	39	38	37	36	35	34	33	32
3	63	62	61	60	59	58	57	56	55	54	53	52	51	50	49	48

Table 8: Fault Bit Mapping

For example: in Figure 9, Fault Set 1 = 0C00 = 0000.0000.0011.0000, which indicates that fault 26 and fault 27 are active. Note that fault positions 55, 56, 58 to 63 are reserved for future use (gray colored cells in above table).

Fault	Description	Severity
0	GFDI Fault	Lockdown
1	IMI Fault	Lockdown
2	Power module heatsink temperature fault	Abort 1
3	Control board temperature fault	Abort 1
4	24V auxiliary supply under voltage	Abort 1
5	Fan fault	Lockdown
6	DC differential over voltage	Abort 1
7	DC differential under voltage	Abort 1
8	Link over voltage	Abort 2
9	Link starving	Abort 2
10	Link over current	Abort 2
11	IGBT VCES over voltage 1	Abort 2
12	IGBT VCES over voltage 2	Abort 2
13	IGBT VCES over voltage 3	Abort 2
14	IGBT VCES over voltage 4	Abort 2
15	AC A-B hard switch	Abort 2
16	AC B-C hard switch	Abort 2
17	AC C-A hard switch	Abort 2
18	DC2 input hard switch	Abort 2
19	DC2 output hard switch	Abort 2

Fault	Description	Severity
28	AC under voltage level 3 trip	Abort 0
29	AC under voltage level 4 trip	Abort 0
30	AC over voltage level 1 trip	Abort 0
31	AC over voltage level 2 trip	Abort 0
32	AC over voltage level 3 trip	Abort 0
33	AC over voltage level 4 trip	Abort 0
34	AC under frequency level 1 trip	Abort 0
35	AC under frequency level 2 trip	Abort 0
36	AC under frequency level 3 trip	Abort 0
37	AC under frequency level 4 trip	Abort 0
38	AC over frequency level 1 trip	Abort 0
39	AC over frequency level 2 trip	Abort 0
40	AC over frequency level 3 trip	Abort 0
41	AC over frequency level 4 trip	Abort 0
42	Watchdog timeout	Abort 2
43	Emergency Stop	Abort 0
44	Sensing fault	Abort 2
45	Arc fault	Abort 0
46	Comms processor-initiated shutdown	Abort 2
47	AC Surge detect	Abort 1

Fault	Description	Severity
20	DC3 input hard switch	Abort 2
21	DC3 output hard switch	Abort 2
22	Link state timer check	Abort 2
23	Bad link start	Abort 2
24	Invalid method/settings	Abort 2
25	Island detected	Abort 0
26	AC under voltage level 1 trip	Abort 0
27	AC under voltage level 2 trip	Abort 0

Fault	Description	Severity
48	AC switch breakdown voltage exceeded	Abort 2
49	DC switch breakdown voltage exceeded	Abort 2
50	Precharge timeout	Alarm
51	Link differential over voltage	Abort 2
52	AC line to line instantaneous over voltage	Abort 1
53	License fault	Abort 2
54	Grid_Ack timeout	Abort 1
57	AC line to ground instantaneous over voltage	Abort 1



11. Warranty

This CE+T Limited Warranty (this “Warranty”) for 30kW battery converters and grid resilient 30kW power conversion systems manufactured by CE+T (“Converters”) is made by CE+T Inc., a Delaware corporation with offices located at 300 Shawnee North Drive, Suite 700, Suwanee-Atlanta, 30024 Georgia.

This Warranty extends to the original purchaser of a Converter (“Buyer”) and to the transferee of a Converter (“End-User” and each of Buyer and End-User, a “Warrantee”) from an authorized distributor of CE+T (“Distributor”) and will become effective on the Effective Date (defined below) and remain in force for a period of ten (10) years (“Warranty Period”). The “Effective Date” shall occur with respect to a Converter on the date when title of such Converter passes to Warrantee (as demonstrated by proof of sale from a Distributor where Warrantee is an End-User); provided, however, in no event shall the Effective Date be postponed more than one.

(1) year after shipment of a Converter from CE+T to a Buyer and then only if purchased through a Distributor. For the avoidance of doubt, for purposes of this Warranty, a “Distributor” shall be considered a “Buyer.”

This Warranty is only valid for Converter(s) purchased and installed in North America.

Converter Warranty

Subject to the terms and conditions herein, CE+T warrants that during the Warranty Period, Converter(s) will (i) be free from material defects in materials and workmanship, and (ii) meet CE+T’s specifications in effect at the time such Converter was made (each, a “**Standard**”).

As Warrantee’s sole and exclusive remedy, and CE+T’s entire liability, for any Converter that does not conform in all material respects to the Standards (such product, a “Defective Converter”), CE+T shall, at its sole option and expense (i) repair such Defective Converter with new and/or reconditioned parts, (ii) replace such Defective Converter with new and/or reconditioned Converters having specifications equal to or better than those in effect at the time the Defective Converter was made, or (iii) refund the purchase price of the Defective Converter, as determined by CE+T.

This Warranty gives the Warrantee specific legal rights, and the Warrantee may also have other rights which vary from state to state.

Warranty Conditions and Exclusions

The warranties provided in Section 3, page 7 are conditioned on the following (each, a “**Warranty Condition**”):

1. The installation, use, operation and maintenance (including with respect to frequency of maintenance) of a Converter in accordance with the CE+T Installation and Operations Manual (as may be amended, restated or otherwise revised from time to time) and any other operating or other manuals relating to such Converter that CE+T may provide to Warrantee from time to time and explicit acknowledgment by Buyer that all Converters require periodic maintenance, as outlined in this unit’s Operation Manual, and it is the responsibility of the Buyer to perform regular maintenance. Failure to properly maintain the unit and perform regular maintenance may void the Warranty,
2. Warrantee making a Claim (defined below) during the Warranty Period,
3. CE+T receiving payment in full for the Converter,
4. If applicable, Warrantee’s complete performance and compliance with the representations and warranties in Section 7, page 18, and
5. No person making any effort to disassemble the Converter or any portion thereof.

In no event shall this Warranty cover any defect, loss, damage, failure or other nonconformity of a Converter (“Excluded Defect”) that are directly or indirectly caused by or arise out of any of the following:

- Failure to commission the inverter within 12 months from the date of the CE+T commercial invoice, or if the inverter has been commissioned, and thereafter shut down or depowered for a period in excess of 12 months;
- Failure to install a secure ethernet network connection to each converter installed at the site;
- Alterations or modifications to a Converter including repairs other than by CE+T or its authorized contractors including, but not limited to, breakage of a Converter’s seal without prior CE+T written consent;
- Warrantee’s or any third-party’s equipment, including, without limitation, components of any system a Converter is integrated into by Warrantee;
- Improper or non-standard installation or operation; including penetrations to the power converter’s enclosure other than the bottom wiring bracket, where all wiring conduit must be correctly installed
- Insufficient ventilation of the device and any consequential thermal damages
- Corrosion due to exposure to aggressive atmospheres or environmental conditions outside the scope of design
- Failure to observe the applicable safety regulations (UL, CSA, VDE, IEC, etc.)
- Use or operation with defective electrical and/or mechanical equipment;
- A force majeure occurrence, including, without limitation, lightning, overvoltage, severe weather, fire, earthquakes and floods, pest damage, or the influence of foreign objects;
- Improper handling during transportation or storage or damage during shipping;
- Failures and/or faults in relation with any third-party accessories;
- Damage or failure caused by negligence, an accident, an object striking the unit, fire, theft, vandalism, contamination, freezing, unapproved installation, modifying or altering the unit, or external influences such as, but not limited to, environmental exposure, abnormal grid power quality, and/or any other misuse;
- This warranty only applies to defects in workmanship and materials which does not include claims involving regulatory compliance. To make sure your Converter meets the applicable regulatory requirements which are in place at the time of purchase, please see the applicable Converter Manuals and/or your sales contract.

The items below are expressly not covered by this CE+T Limited Factory Warranty:

- All items not originally sold by CE+T including, but not limited to, installed cables, controllers, (rechargeable) batteries, Current Transformers (CT), Voltage Transformers (VT), and communications devices;
- Consumables and parts subject to regular wear and tear (including, but not limited to, varistors, surge arresters, string fuses, ESS handles, filters, (rechargeable) batteries, or overvoltage protection devices);
- Cosmetic or finish defects which do not directly influence energy production, or degrade form, fit, function;
- The warranty does not cover travel and accommodation costs as well as onsite assembly, installation, or maintenance costs related to repair or replacement of the Converter.
- Changes to the existing PV system, the building installation and the like, or any expenditure of time and the costs resulting from this are not covered by the warranty;
- Compensation for damages related to loss of power production or business operation or any expenses incurred by customer towards repair, removal and/or replacement of the Converter (including but not limited to labor, transportation, temporary power);



- Damages arising because the use of the Converter for the intended purpose is no longer possible or only possible with restrictions as a result of amendments to the statutory provisions applicable to the operation of the Converter made after the delivery of the Converter.

Warranty Claim Process

During the Warranty Period (and at no other time), Warrantee may make a claim (“Claim”) under this Warranty if it believes a Converter it purchased is a Defective Converter by contacting CE+T directly at customer.support@cet-power.com or +1 855-669-4627 and providing the following information:

- Converter model number and serial number;
- Description of the Converter failure, including copies of pertinent Fault Logs and Power-On-Self-Test (POST) Logs;
- Proof of purchase; and
- Current location of the Converter.

Upon receipt and acceptance by CE+T of a Claim, CE+T will elect, at its sole option, to inspect, repair and/or replace, as applicable, the Converter(s) relating to such Claim at (i) CE+T’s facilities or another service location of CE+T’s choosing or (ii) such Converter’s then current location (“Field Service”, and collectively, “Warranty Services”), and shall notify Warrantee of its election.

Claim Acceptance; Responsibility for Expenses

- A) If CE+T determines the Converter does not conform in all material respects to the Standards, and the Claim is not otherwise excluded from this Warranty, such Claim shall be deemed “accepted” and CE+T shall remedy such Claim pursuant to Section 1.
- B) Notwithstanding anything to the contrary contained herein, in CE+T’s Terms and Conditions of Sale for Power Conversion Products entered into by CE+T and Warrantee (“Sales Terms”), if any, or in Warrantee’s Converter purchase order (“Purchase Order”), if CE+T determines, in its professional opinion, that, with respect to a Converter that is the subject of a Claim, (i) such Product conforms in all material respects to the Standards, (ii) any Warranty Condition has not been met, or (iii) the claimed defect is an Excluded Defect, the claim shall be deemed “not covered” and CE+T shall provide a written repair quote, which must be accepted by Warrantee prior to commencement of repair. Warrantee will be invoiced for authorized repairs, alteration or services performed on such Converter upon return shipment.

The below table sets forth the expenses to be borne by each party in the event a Claim is (i) “accepted” pursuant to Section 4(a), or (ii) “not covered” pursuant to Section 4(b).

Item	Party Responsible	
	Accepted Claims	Claims not Covered by This Warranty
Removal and re-installation of Converter	Warrantee	Warrantee
Repair labor	CE+T	Warrantee, at CE+T’s standard rates
Spare parts and materials	CE+T	Warrantee
Travel expenses and per diem	Warrantee	Warrantee
Troubleshooting / Cause determination on Converter	CE+T	Warrantee
Shipping Costs	Warrantee	Warrantee
Administration service processing fees	CE+T	Warrantee



Field Service Representations and Warranties

Warrantee represents and warrants that during CE+T's performance of Field Service, it will provide, or cause to be provided:

- A) Full, barrier-free access to the subject Converter;
- B) All resources necessary to inspect, repair or replace, as applicable, the subject Converter, including safety or lifting equipment, upon CE+T's request; and
- C) Authorization for CE+T to enter any premises where the subject Converter is located.

Assignment and Subcontracting

This Warranty is personal to Warrantee and may not be assigned or otherwise transferred (except from a Distributor to an End-User), in whole or in part, without CE+T's prior written consent, such consent to be granted or withheld in CE+T's sole discretion. CE+T may, in its sole discretion, subcontract the performance of any Warranty Services to any third-party; provided (i) such third-party is, in CE+T's professional opinion, qualified to perform such Warranty Services and (ii) CE+T shall remain responsible for performance of any such Warranty Services by its subcontractors. For purposes of Sections 3 and 5, the term "CE+T" shall mean "CE+T or its authorized contractor."

Disclaimer and Limitation of Liability; Waiver of Consumer Rights

The limited warranty described herein shall be the sole and exclusive warranty granted by CE+T where permitted by law, and shall be the sole and exclusive remedy available to warrantee. To the maximum extent permitted by law, CE+T expressly disclaims all other warranties, express or implied, including without limitation any warranty of merchantability, warranty for fitness for a particular purpose, and any warranties that may have arisen from course of dealing or usage of trade. Without limiting the foregoing, no implied warranty shall apply to any product after the expiration or termination of the warranty period. Some states or jurisdictions do not allow limitations on how long an implied warranty lasts, so the above limitation may not apply to the warrantee.

To the maximum extent permitted by law, CE+T's aggregate monetary liability to warrantee and any third-party for any reason and for all causes of action, whether in contract, tort or otherwise, will not exceed the amount paid to CE+T for the product covered by this warranty. Under no circumstances shall CE+T be liable for incidental, consequential, or special damages however caused, even if CE+T has been advised of the possibility of such damages. Some states or jurisdictions do not allow the exclusion or limitation of incidental or consequential damages, so the above limitations or exclusions may not apply to the warrantee.

Warrantee hereby waives its rights under the Texas deceptive trade practices-consumer protection act, section 17.41 et seq., business & commerce code, a law that gives consumers special rights and protections. After consultation with an attorney of warrantee's own selection, warrantee hereby voluntarily consents to this waiver.

Dispute Resolution

- A) Informal Resolution. CE+T and Warrantee shall attempt in good faith to resolve any dispute, controversy or claim arising out of or relating to this Warranty, or the breach, termination, or invalidity thereof (each, a "Dispute") by negotiation and consultation between themselves.
- B) Arbitration. If any Dispute remains unresolved after ten (10) days of informal resolution attempts, promptly upon written request from either CE+T or Warrantee to the other, such Dispute shall be submitted for arbitration to be administered by the American Arbitration Association in accordance with its Commercial Arbitration Rules. The arbitration proceedings shall be conducted before a panel of three neutral arbitrators, all of whom shall be members of the bar of the State of Texas. The arbitration, including the rendering of the award, shall take place in Austin, Texas. Judgment on the award rendered by the arbitrator(s) may be entered in any court having jurisdiction thereof. The language to be used in the arbitration shall be English. Except as may be required by law or to enforce the award, none of CE+T, Warrantee or any arbitrator may disclose the existence, content, or results of any arbitration hereunder without the prior written consent of all parties to the arbitration proceeding.



C) Exclusive Remedy. The procedures set forth in this Section shall be the exclusive remedy and mechanism for resolving any Dispute that may arise from time to time. Warrantee must seek resolution of any Dispute utilizing the mechanisms and procedures in this Section prior to pursuing any legal remedy in the courts. For the avoidance of doubt, Warrantee may not seek relief for any Dispute against CE+T in any court under the Magnuson-Moss Warranty-Federal Trade Commission Improvement Act (15 U.S.C. §§ 2301-2312), or any other laws or regulations, prior to fully exhausting its rights and remedies under this Section.

D) Survival. The terms of this Section shall survive any termination or expiration of this Warranty.

Payment Terms

If Warrantee owes CE+T any amounts under this Warranty, payment terms shall be net thirty (30) days after the date of CE+T's invoice. Payments made after the due date are subject to a 1.5% per month late payment services charge or, if less, the maximum rate allowed by law.

Interpretation

To the extent a Converter that is subject to this Warranty is also subject to Sales Terms, this Warranty is provided in conjunction with such Sales Terms. To the extent there is any inconsistency between this Warranty and any applicable Sales Terms, such Sales Terms order shall control if, and only if, such Sales Terms expressly reference this Warranty, and that the Sales Terms shall control.

End of Document